



**Chromalloy location
Carson City, Nevada**

Custom Solutions for Today's Manufacturing Environment

Chromalloy Gas Turbine Corporation is a pioneer in the high temperature coating of jet aircraft engine vanes and blades. In 1951 Chromalloy Gas Turbine Corporation developed a high temperature diffusion coating to provide oxidation protection on nozzle guide vanes. From the first generation of commercial airliners to today's supersonic military aircraft, Chromalloy has led the way with the most advanced coating technologies in their industry.

Chromalloy approached J & D Associates for a solution to their treating and dipping process. J & D Associates engineering designed a solution for their curing process. It involved creating and manufacturing customer carriers for Chromalloy's unique molds used in their

manufacturing process.



The carriers are custom made to accommodate specific parts for Chromalloy's needs. Each carrier has 74 possible positions which can hold up to 19 small molds or

15 large molds. The molds hang from the carriers and are rotated vertically. The clamp holds the molds in position as they are taken off and rotated. There are 13 carriers on one machine giving it the capacity to hold from 195 to 247 molds.

The machine itself is fitted with full sheeting to accommodate Chromalloy's clean room manufacturing environment.

Contact J & D Associates for solutions to today's increasing demand on innovative solutions to your customer's manufacturing needs. Engineering is a key component to finding solutions to today's manufacturing environment.

**Contact J & D Associates
for solutions to your
customer's requirements!**

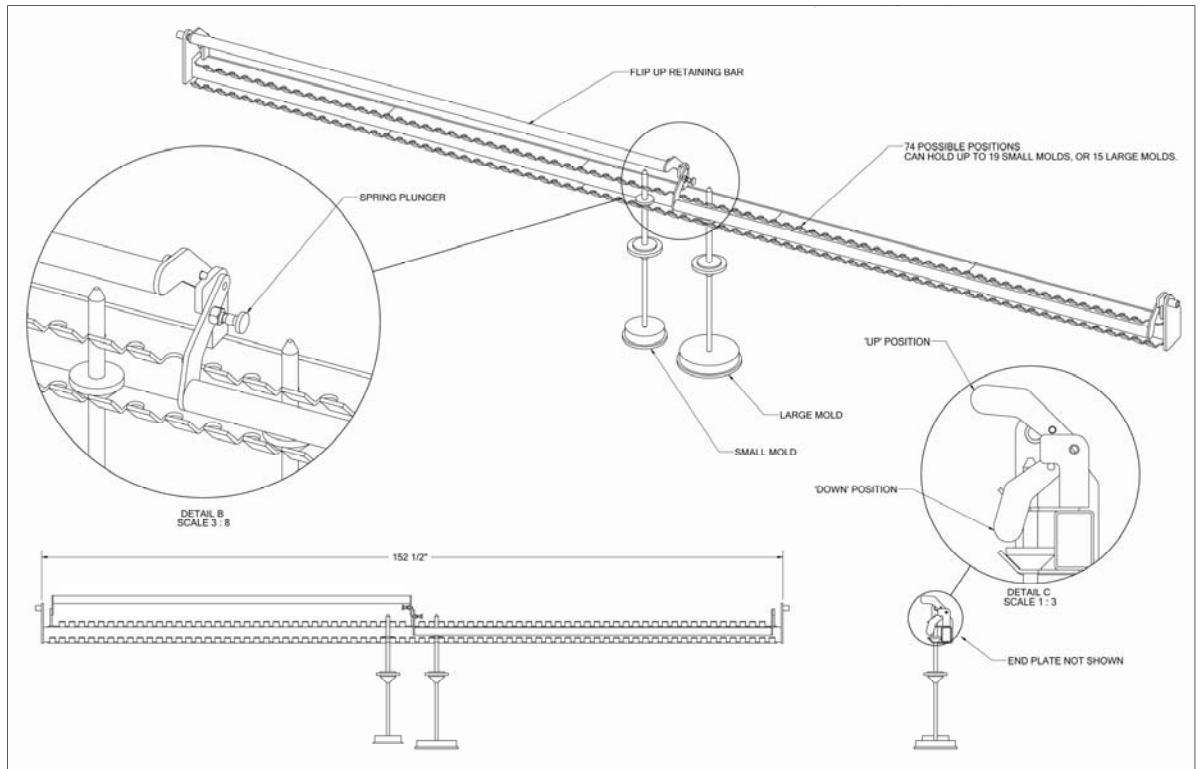

Shur-Co® is the leading manufacturer of tarp systems and components. Shur-Co® has been providing the agriculture and automotive industries with safe, reliable and cost-effective solutions to their tarp needs for over 50 years. Shur-Co® provides the best tarping systems

Before installing a RollMaster Vertical Carousel (VC), Shur-Co® utilized an "A" frame static holder that was limited to a five roll capacity. After installing the RollMaster VC, Shur-Co® realized a savings in space, the ability to complete a production shift without restocking the

extrusions on roll-carts. After the Bar Stock VC was installed, eight major extrusions were brought to the handling area at the push of a button.

Shur-Co® not only saved time and floor space, but also freed up a person and a half (per shift) to do other duties besides just handling material.

Whether you need to organize, secure, pull-off, rotate, measure, cut or maximize your floor space, J & D Associates has a system to meet your needs!



" Increased Productivity and Less Downtime are a Major Advantage in Production Thanks to J & D"

**Kristi Palacek
Production Manager**



available on the market . Whether the application is for construction, agriculture, fertilizer, aggregates, mineral, waste or scrap, Shur-Co® has the solution.

Material handling is a critical component at Shur-Co® in their tarp assembly process. J & D Associates introduced Shur-Co® to the concept of going vertical at the International Fabric's Association trade event.

carousel, providing a faster set-up time and the ability to change stock immediately.

Shur-Co® not only realized efficiencies in their rolled goods handling but also brought the concept of going vertical to another aspect of material handling, aluminum extrusions.

Prior to having a Bar Stock Vertical Carousel installed, Shur-Co® handled their



Bar Stock Vertical Carousel



RollMaster Vertical Carousel

J & D Associates

600 Hunter Lane
Middletown, PA 17057

Phone: (717) 930-0622
Fax: (717) 930-0648
Email: info@jdstorage.com



New Employees

Nancy Gavin	Customer Service Representative
Mike White	Lighting Group
Neal Marter	Lighting Group
Kevin Tate	Lighting Group
Keith Mays	Lighting Group
Matt Tozeski	Lighting Group
Robert Koense	Lighting Group
James Hainesworth	Lighting Group
William Baker	Lighting Group
Clint McConnell	Racking Group
Debra Torres	Racking Group

And the Winner Is!

The ISP sales contest which was run from June 30 2004 through June 30 2005 is now complete. While there were quite a few ISP's who were in the competition, one stood out from the rest.

Congratulations go out to Perry Graehling of Material Systemation in Ohio. Perry's contribution of selling eight machines tops all other's in the sales contest. Perry is receiving a gift certificate of \$2,000.00 that can be redeemed from AAA Travel.

All Perry has to do now is redeem it for a dream vacation to any place he chooses. Thank you, Perry, for an outstanding year. J & D Associates looks forward to your continued contributions and sales efforts.

Tom Wolf

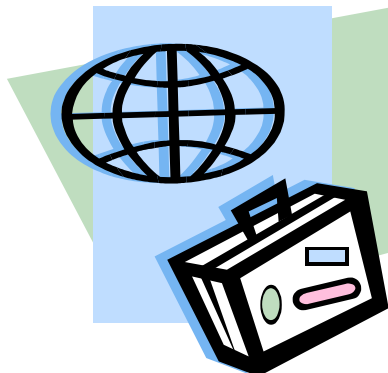

A Message from Marketing

Happy New Year! Even though it sounds a bit strange in July, it is appropriate for J&D Associates. Our 2004-2005 fiscal year ended in June and the 2005-2006 fiscal year started in July. As you can see, for J&D, it truly is a new year.

With the new year comes new sales goals. Our Regional Sales Managers have their individual sales quotas. They are doing their best to meet or beat monthly and quarterly objectives. Their success depends upon your contribution. Consequently, you will be contacted by them

to discuss how we may best support your efforts to assure our continued success.

Last year was a good year for J&D Industrial Sales. On behalf of the J&D Industrial Sales Team, I would like to thank you, Industrial Sales Partners, for your sales efforts, your fair share of mind and your contribution to our success. With your help we were able to increase our net sales by 42% over the previous year. Again, we thank you for your past efforts and solicit your continued support as we move into our new fiscal year.



Walt Sener, Director of Sales and Marketing

For our mutual benefits, keep up the good work.

